

# Air Intake Shut-off Valve

Model 7001

## Overview

Hydraulic fracturing technology requires the use of heavy-duty, high-horsepower diesel engines. Hydrocarbons released in an area where a diesel engine is operating can lead to diesel engine runaway which can be a highly dangerous situation. Once an engine begins to run on the external fuel source, turning off the ignition will have no effect. The engine will continue to run out of control, leading to mechanical failure and, potentially, an explosion. The AMOT 7001 Series air intake shutoff valve was designed for the harsh wear and tear of the frac industry. The valve will effectively shut down a runaway diesel engine by closing off engine intake air.



## Key features and benefits

- IP 67 Rated solenoid/actuator is enclosed for reliable performance
- Anodized aluminum and stainless steel construction resists corrosion
- Rugged and reliable performance in continuous working temperature from -40°C to 100°C
- Designed for post-turbo temperatures
- Designed for high-vibration environments
- Elbow kit (if needed) consists of male/female o-ring marmon flange connections that allow direct bolt on to MTU Series 4000 engines (S81/S82/S83)
- Position switch integrated into actuator housing for protection from charge air temperature and debris

## Typical Applications

**MTU Series 4000 (S81/S82/S83) high horsepower engines used in the following applications:**

- Hydraulic fracturing units
- Offshore production engines
- Hazardous material vehicles
- Marine engines
- Bulk fuel haulers (tankers)
- Power generation (gen sets)
- Mining equipment
- Locomotives
- Fuel transfer pumps
- Fire pumps



# Air Intake Shut-off Valve

Model 7001

## Dimensions

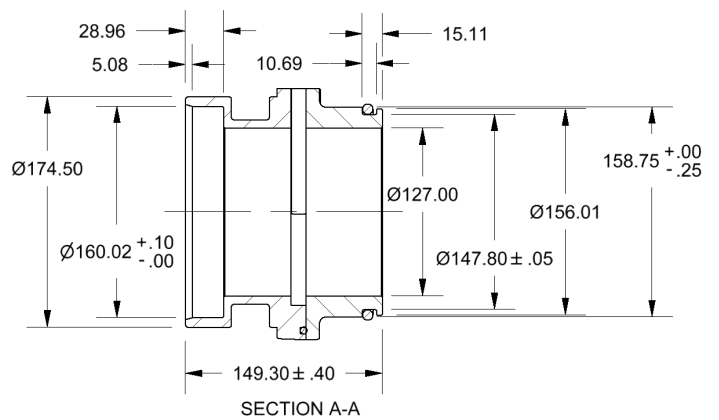
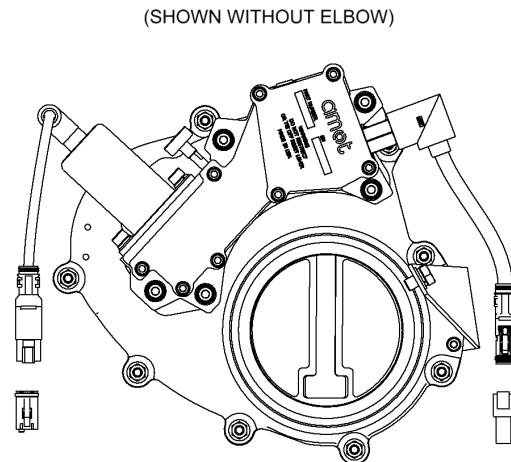
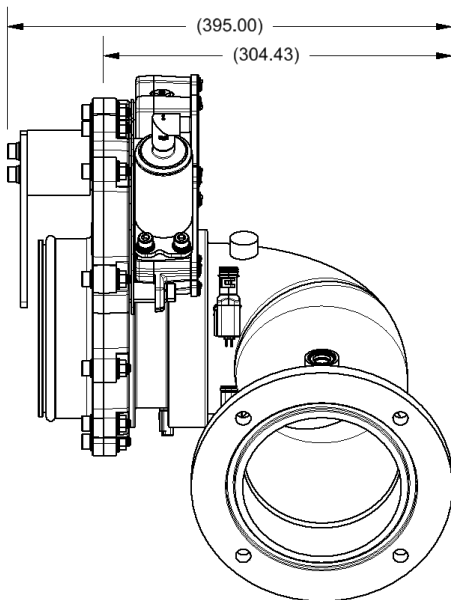
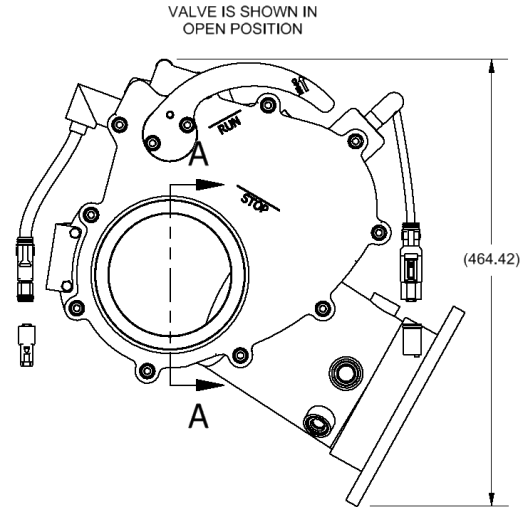
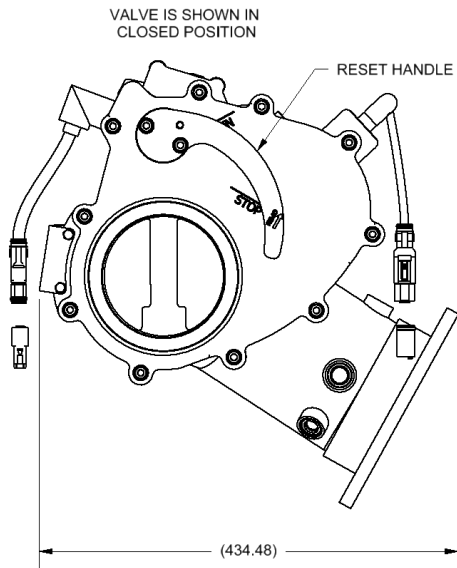

# Air Intake Shut-off Valve

Model 7001

## Specifications

<b>Standard materials</b>	Valve body & actuator housing	Hard anodized aluminum
	Gate	Brass
	Seals	Viton/Silicone
<b>Maximum intake air temperature</b>	-40°C to 100°C	-40°F to 212°F
<b>Valve Size</b>	5" valve size	127 mm
<b>Net weight</b> (without elbow kit)	15 kg (34 lbs)	
<b>Max Charge Air Pressure</b>	5 bar	72 psi
<b>Solenoid</b>	Voltage	16.8 - 31.2 Volts DC
	Max current draw	42.2 A @ 31.2 VDC & -40°C
	Inductance	3.5mH ±40°C
	Actuation Sequence @ 31.2 VDC, 100°C	Max 2s ON, Min 1s OFF Max 2s ON, Min 300s OFF
	Actuation Sequence @ 24 VDC, 25°C	Max 2s ON, Min 1s OFF Max 2s ON, Min 60s OFF
<b>Switch</b>	5 Amp resistive load max >0.25W	

## Service Kits & Accessories

Part Number	Description
RKS-7001-04	Solenoid kit
RKS-7001-09	Reset handle
RKS-7002-04	Normally-closed switch kit
RKS-7002-01	Normally-open switch kit
4009-077	Flange o-ring
1641-019	Timer relay, 24 VDC

